

STAGE RACER 2 INSTALLATION MANUAL

DECENTRALISED ROUTING, DISTRIBUTION
AND PROCESSING



CONTENTS

1	DETAILED DESCRIPTION	3
1.1	Small form factor / Integration	3
1.2	Connectors location.....	4
1.3	Interfaces Description/ Ports Mode.....	5
1.3.1	General Purpose IN	5
1.3.2	General Purpose OUT	6
1.3.3	Analog AUDIO.....	7
1.3.4	AES / MADI	8
1.3.5	AoIP DANTE / AES-67	8
1.3.6	SDI Embedding / De-Embedding.....	8
1.3.7	Serial ports	9
1.3.8	Ethernet ports/ Mode.....	10
1.3.9	Admin port.....	10
1.3.10	Genlock/Composite VIDEO port	10
1.3.11	SDI VIDEO ports	11
1.3.12	OPTICAL transmission ports.....	11
1.4	Visualisation	13
1.4.1	General Status	13
1.4.2	Trunks	13
1.4.3	Expansion.....	14
1.4.4	Video Status Leds	14
1.4.5	Serial and IP	14
1.4.6	AUDIO	15
1.4.7	GPIO	15
1.4.8	OLED Display.....	16
1.5	Optional Connectors.....	17
1.5.1	Description	17
1.5.2	RS422 option pinout.....	17
2	TECHNICAL SPECIFICATIONS.....	18
2.1	Main Hardware.....	18
2.2	Options.....	19

Further information is available in the Stage Racer2 Technical Manual.
[Please contact us](#) for a copy.

1 DETAILED DESCRIPTION

1.1 SMALL FORM FACTOR / INTEGRATION

The Stage Racer 2 is a 1RU rack solution ideally designed for space restricted installations. Chassis depth is 330mm excluding connectors.

The Stage Racer 2 benefit from a very well-studied thermal conception and can operate from -20°C to +60°C. The internal fans speed is automatically adjusted depending on the internal motherboard temperature. At room temperature, the fans run at minimal speed allowing the Stage Racer 2 to be used in a quiet environment.

For field application a 4 to 5 RU fly case integration offers sufficient room for properly expending all the connections on panel BNC and XLR sockets.

Care should be taken regarding heat accumulation when proceeding to a flight case or any closed container integration. It is important to understand the airflow of the unit and not to obstruct the air inlet and outlet located on the side of the unit (see drawing below).

If space is limited, it is more important to allow more space for the air outlet using a small grille located in regard of the stage racer exhaust grille.

Alternatively, a forced air cooling of the flight case would be sufficient as well.

Air outlet

CAUTION: Do not obstruct with rackmount extra supports.

-Minimum clearance 60mm

-Best is small grille on flycases integration

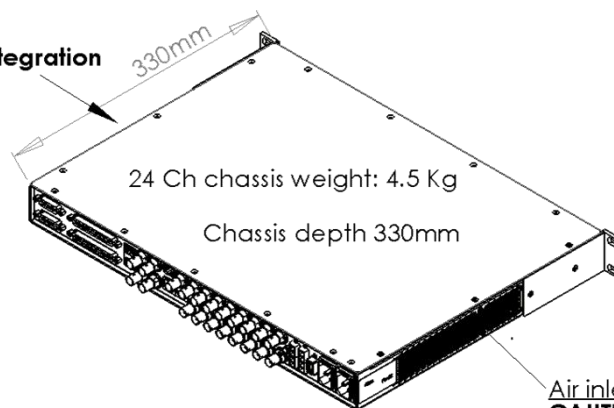

Air inlet

CAUTION: Do not obstruct with rackmount extra supports.

-Minimum clearance 40mm

1.2 CONNECTORS LOCATION

The Stage Racer 2 provides signals, optical and power connectors on the rear panel. Optional Serial connectors and optional DC power are fitted on the visualization panel.

• Rear connectors

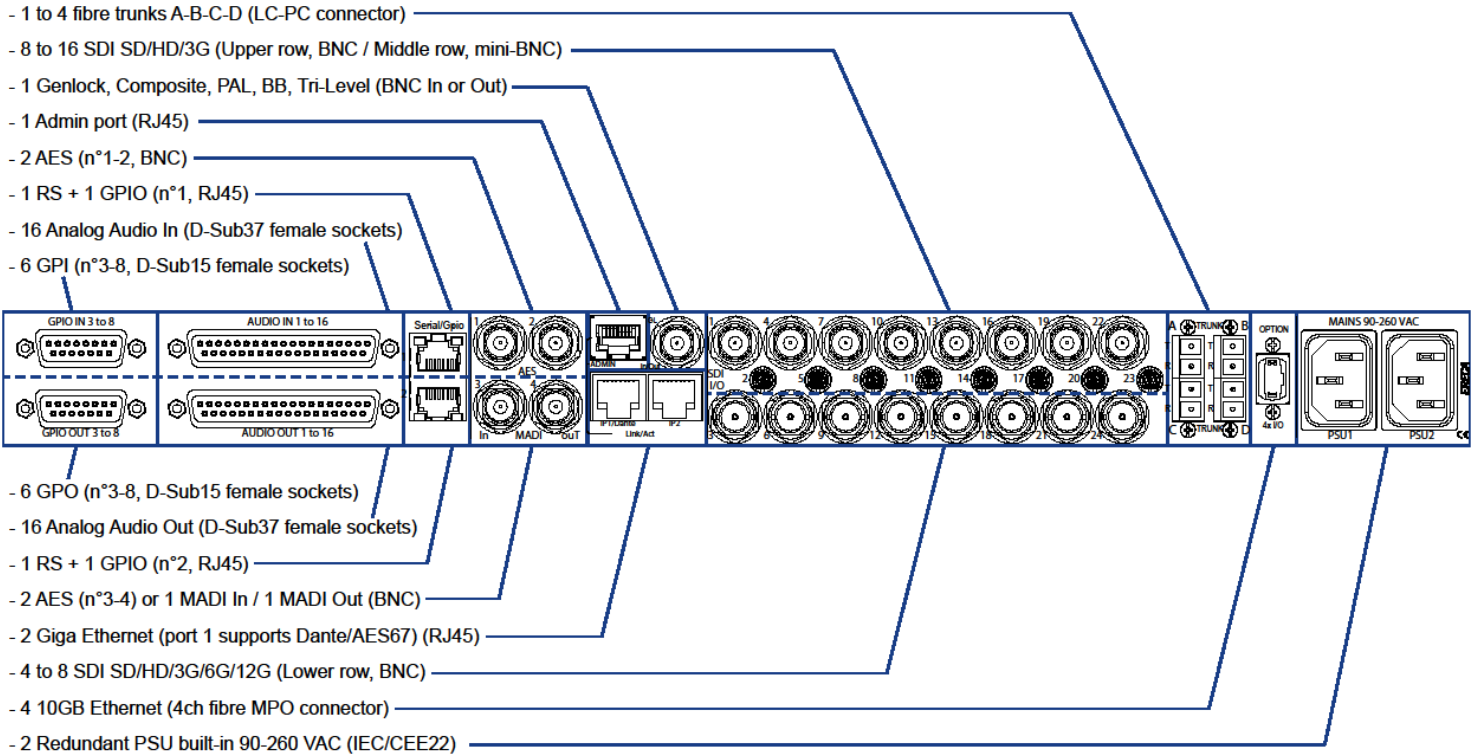

• Front connectors (For Serial and DC Power options)



1.3 INTERFACES DESCRIPTION/ PORTS MODE

This section includes the pinout for all electrical access and describes protocol audio interfaces such as MADI / SDI embedded Audio / Dante. For SDI, MADI and Ethernet the input process is also described in this section in order to keep concise documentation.

1.3.1 General Purpose IN

For forward product compatibility the GP IN section is split on two kind of connectors.

Inputs 1 and 2 are shared with each Serial signal transmission RJ 45 terminal, labeled "Serial/Gpio". These inputs are protected by an opto-coupler but are not floating; a grounding on the input pin triggers the GP-IN.

	1: GND 2: GP IN 3: RX RS 422 – or RX RS 232 4: TX RS 422 – or TX RS 232 5: TX RS 422 + 6: RX RS 422 + 7: GP OUT 8: GP OUT
--	--

Inputs 3 to 8 are on one D-SUB 15 terminal female socket. Inputs are independent and electrically isolated by opto-couplers. Each input is non-polarised and feature an automatic 5mA current limitation working with an input voltage of 5 to 24 volts. The wiring polarity does not matter in this case.

Ground and power pins are available on the connector to ease interfacing with others machines especially if a dry contact, open connector or ground closure supplies the information.

The 12 volts output of the Stage Racer 2 is protected against external short circuit by an internal 100mA resettable fuse (polyswitch) common to the GPI and GPO sockets.

GP IN N°	SIGNAL	Socket contact	D SUB 15 GP IN	Socket contact	SIGNAL
3	GP IN 3a	1		9	GP IN 3b
4	GP IN 4a	2		10	GP IN 4b
5	GP IN 5a	3		11	GP IN 5b
6	GP IN 6a	4		12	GP IN 6b
7	GP IN 7a	5		13	GP IN 7b
8	GP IN 8a	6		14	GP IN 8b
	GND (0V)	7		15	+ 12V 100 mA
	GND (0V)	8			

Example: GP IN 3 (with dry contact, ground closure, open collector drive).

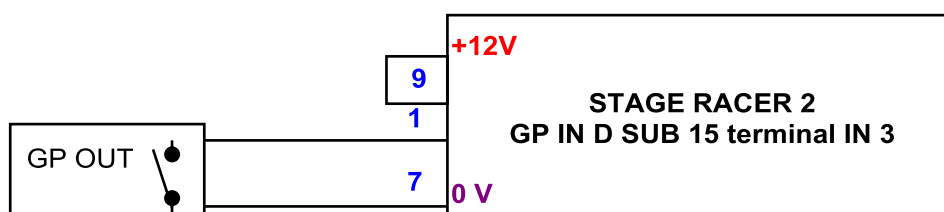

1.3.2 General Purpose OUT

For forward product compatibility the GP OUT section is split on two kind of connectors.

Outputs 1 and 2 are shared with each Serial signal transmission RJ 45 terminal, labeled " Serial/Gpio ". These outputs are on floating dry contact relays with 50 Volts AC/DC and 0.25A switching capacity. The relay is open if the corresponding remote input is not triggered.

	1: GND 2: GP IN 3: RX RS 422 – or RX RS 232 4: TX RS 422 – or TX RS 232 5: TX RS 422 + 6: RX RS 422 + 7: GP OUT 8: GP OUT
---	--

Outputs 3 to 8 are on one D-SUB 15 terminal female socket. These outputs are also on floating dry contact relays with 50 Volts AC/DC and 0.25A switching capacity. The relay is also open if the corresponding remote input is not triggered.

Ground and power pins are available on the connector to ease interfacing with others machines especially if the driven machine need a voltage information rather than a contact closure.

The 12 volts output of the Stage Racer 2 is protected against external short circuit by an internal 100mA resettable fuse (polyswitch) common to GPI and GPO sockets.

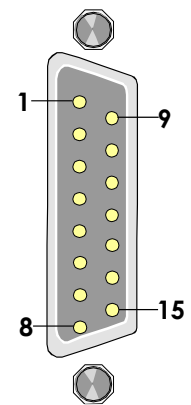
Relay N°	SIGNAL	Socket contact	D SUB 15 GP OUT	Socket contact	SIGNAL
3	GP OUT 3a	1		9	GP OUT 3b
4	GP OUT 4a	2		10	GP OUT 4b
5	GP OUT 5a	3		11	GP OUT 5b
6	GP OUT 6a	4		12	GP OUT 6b
7	GP OUT 7a	5		13	GP OUT 7b
8	GP OUT 8a	6		14	GP OUT 8b
	GND (0V)	7		15	+ 12V 100 mA
	GND (0V)	8			

Each GPI can be affected to one or Multiple GPO by using the GPIO routing grid of the Stage racer 2.

1.3.3 Analog AUDIO

1.3.3.1 Pinout

One D-SUB 37 pin female socket provides the access to the 16 balanced analog AUDIO IN.
 One D-SUB 37 pin female socket provides the access to the 16 balanced analog AUDIO OUT.

SIGNAL	Socket contact	D SUB 37 AUDIO In/Out	Socket contact	SIGNAL
AUDIO 1 +	1		20	AUDIO 1 -
AUDIO 2 +	2		21	AUDIO 2 -
AUDIO 3 +	3		22	AUDIO 3 -
AUDIO 4 +	4		23	AUDIO 4 -
AUDIO 5 +	5		24	AUDIO 5 -
GND	6		25	GND
AUDIO 6 +	7		26	AUDIO 6 -
AUDIO 7 +	8		27	AUDIO 7 -
AUDIO 8 +	9		28	AUDIO 8 -
AUDIO 9 +	10		29	AUDIO 9 -
AUDIO 10 +	11		30	AUDIO 10 -
GND	12		31	GND
AUDIO 11 +	13		32	AUDIO 11 -
AUDIO 12 +	14		33	AUDIO 12 -
AUDIO 13 +	15		34	AUDIO 13 -
AUDIO 14 +	16		35	AUDIO 14 -
AUDIO 15 +	17		36	AUDIO 15 -
GND	18			
AUDIO 16 +	19		37	AUDIO 16 -

It is possible to set a -30dB attenuator on each individual output from the web interface.

1.3.3.2 Audio Mic gain (optional module)

The gain blocks are connected to channels 9 to 16.

Thru the web server each input 9 to 16 can be amplified independently with a gain ranging from 9 to 60 dB (3dB steps) with or without Phantom power supply.

If the gain on a channel is not desired the gain block can be totally bypassed and the input recovers the line input level.

The phantom power capacity is 10mA for each channel.

Caution: Beware of the input phantom power, after switching off the phantom power the 48Volts will still be present for few seconds on the inputs, time needed by the inputs capacitor to discharge thru the internal discharge resistor.

Note: The Mic gain board can be fitted afterwards.

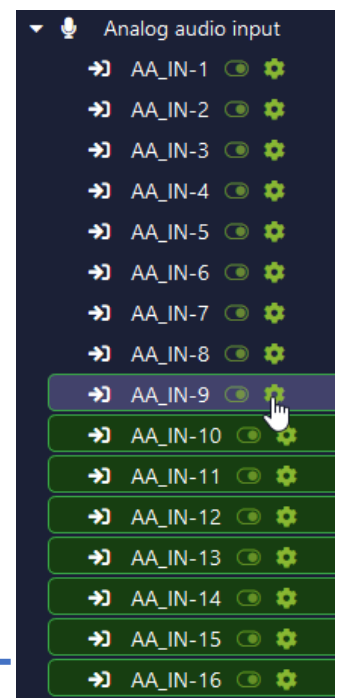

1.3.4 AES / MADI

Digital audio is available on true 75 Ohms BNC sockets.

The total capacity of the Stage Racer 2 is 4 simultaneous bidirectional AES signals. Thru the web server, the AES 3 and 4 can be disabled to allow for MADI.

Caution: Avoid connecting 50 ohms plugs it will damage the socket central pin causing costly repair especially if this one is on the lower part of the connector side.

1.3.4.1 Bidirectional AES

Each AES port is internally equipped with a 2-4 wire converter connected to transmit a fully bidirectional path to any distant AES port of the Stage Racer 2 network. It appears in the AES audio grid of the network.

This allow to interconnect talkback panels working in a bidirectional manner on one 75 Ohms coax. The ports still can be used without configuration to transport unidirectional signal, no setup needed for channel direction.

Note1: For the internal 2-4 wire converter correct behavior the source/terminal impedance of the machine connected to the AES ports must be 75 Ohms.

Note2: The bidirectional function of the device constraint the design specially to provide an accurate AES activity led display and avoid signal loop if port impedance is not 75 ohms. The internal FPGA seeks for AES3 audio XYZ preamble at 48KHz to light the corresponding AES Led and enable transmission in this direction.

1.3.4.2 MADI

When selected through the web server, MADI can be transmitted and port 3 become MADI input and port 4 become MADI output.

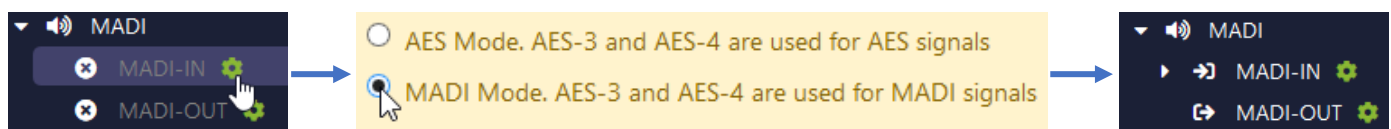

Stage racer 2 offers 2 principles for MADI transmission described below.

Cf. technical manual for more precisions

1.3.5 AoIP DANTE / AES-67

The AoIP board Dante / AES-67 is an optional hardware module provided by Ereca, which provides 64 channels in and out.

To quickly check if you unit is equipped with it, connect to the web server, go "Graph", "Tree view" on the left, select the "SR2 node", then "Dante".

You should see "Dante-IN & OUT BRKLYN-II".

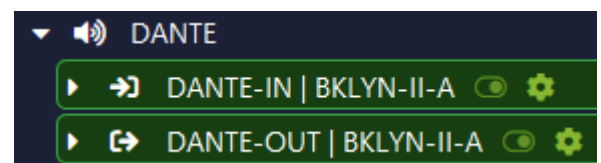

Cf. technical manual for more precisions

1.3.6 SDI Embedding / De-Embedding.

Cf. technical manual for more precisions

1.3.7 Serial ports

Two multiprotocol RS232/422/485 serial signals are transmitted in standard by the equipment.
The supported data rate of each signal is about 500Kbds.

The setting of the serial protocol is done within the web server of the Stage Racer 2.

1.3.7.1 RS422/485

The RJ 45 connector provide 1 differential pair for RS422 transmission and 1 differential pair for RS422 reception.

To build a half-duplex RS485 transmission, just bridge "pin 3 with pin 4" and "pin 5 with pin 6".

For RS485, setup the corresponding Baud rate within the web server to enable the Stage Racer 2 to manage the output impedance at the right serial byte duration.

Connect the Shield to pin 1.

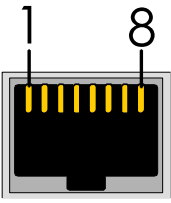
	<p>1: GND (Shield) 2: GP IN 3: RX RS 422 – (Stage Racer 2 electrical OUTPUT) 4: TX RS 422 – (Stage Racer 2 electrical INPUT) 5: TX RS 422 + (Stage Racer 2 electrical INPUT) 6: RX RS 422 + (Stage Racer 2 electrical OUTPUT) 7: GP OUT 8: GP OUT</p>
--	--

Note: For RS 485 Telex/RTS talkback panels please ask ERECA for wiring tip.

1.3.7.2 RS232

Refer The RS 232 signal ground to pin 1. Leave pins 5 and 6 unconnected.

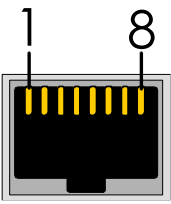
	<p>1: GND (Ground ref/Shield) 2: GP IN 3: RX RS 232 – (Stage Racer 2 electrical OUTPUT) 4: TX RS 232 – (Stage Racer 2 electrical INPUT) 5: Do not connect 6: Do not connect 7: GP OUT 8: GP OUT</p>
---	--

Those serial ports appear in the RS232/422/485 grid and are connectable in a peer 2 peer manner.

1.3.8 Ethernet ports/ Mode

The Stage Racer 2 offers 2 independent Gigabit Ethernet ports, which can either be isolated or connected together through an internal switch. Setting is done in the web GUI.

- When they are isolated, they behave like two completely separate ports which enables to create totally independent Peer to Peer connections over the Stage racer 2 network.

- When the ports are connected, they can communicate with each other through an internal switch. Thus, it allows to create a distributed switch along the Stage racer 2 network in a daisy chained manner.

Note: The extremity nodes of the daisy chain can be isolated or connected. If they are isolated the remaining port can be used to create another separate network connection.

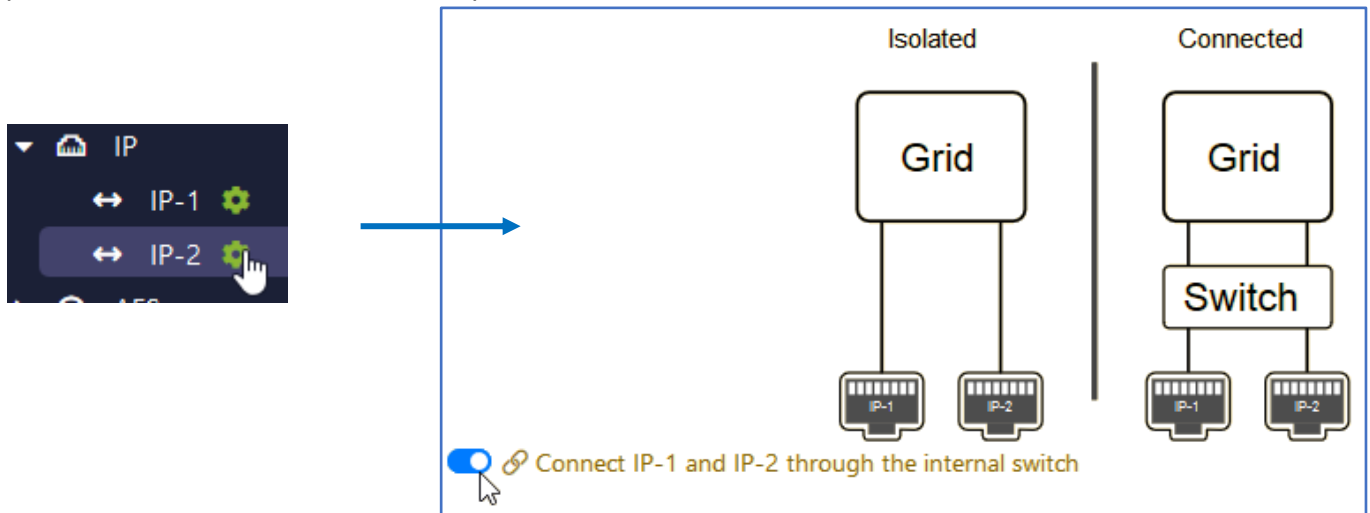

Note1: The Dante board is available on port IP-1 only.

Note2: Port speed is 10/100/1000Mbps Autosense and support straight or crossed cables.

1.3.9 Admin port

The Stage Racer 2 is equipped with a dedicated admin port to access the web interface. Port speed is 10/100Mbps Autosense and support straight or crossed cables.

The IP of the machine can be found using the navigation buttons next to the LCD INFO screen.

Firefox browser is recommended for Gui usage.

1.3.10 Genlock/Composite VIDEO port

This port supports Composite PAL, SECAM & NTSC / Black Burst / Tri-level sync compatible is transmitted thru the Stage Racer 2 via the G/L port.

In a Stage Racer 2 network, the G/L port is direction switchable and work as follows: when the Genlock port direction is set to input on a particular unit, the direction of all the other Genlock ports of all units connected to the network will automatically be set to output. Then genlock is distributed to all the machines over the network.

Composite video is carefully processed with Minimal latency and high-quality process with +/-3dB AGC input, 2x over sampling and 10 bits digital filtering and transmission is provided for this signal. Internally each machine extracts Video and Audio genlocked clocks for frame buffering purposes.

1.3.11 SDI VIDEO ports

Depending on the choice at the time of order, the Stage Racer 2 can be built with either 12 or 24 video channels. Please note it is not possible to upgrade from 12 to 24ch.

The 8 BNC of the upper row and 8 mini-BNC of the middle row can accept SD/HD/3G signals. The 8 BNC of the lower row can accept SD/HD/3G/6G/12G.

Each video port is direction switchable helping user to avoid congestion at locations with highly unbalanced number of Inputs or Outputs.

Each interface will automatically accept a standard at equal or lower rate than the standard set in the machine.

Caution: Avoid connecting 50 ohms plugs it will damage the socket central pin causing costly repair especially if this one is on the lower part of the connector side.

Note: ASI support is internally developed but not yet validated.

1.3.12 OPTICAL transmission ports

1.3.12.1 Optical connection

The Stage Racer 2 transmission is based on TDM multiplexing for the all signals managed by the system. Each TDM multiplex is transmitted to another machine by "Trunk" ports.

Each unit can have up to 4 trunk ports on dual LC/PC socket for Single Mode fiber (minimum is 1 for a network endpoint).

Trunks are labelled A-B-C-D and can be connected randomly as long as the duplex fiber is connected properly : (Tx & Rx of the same trunk -> Rx & Tx of another trunk of a different unit).

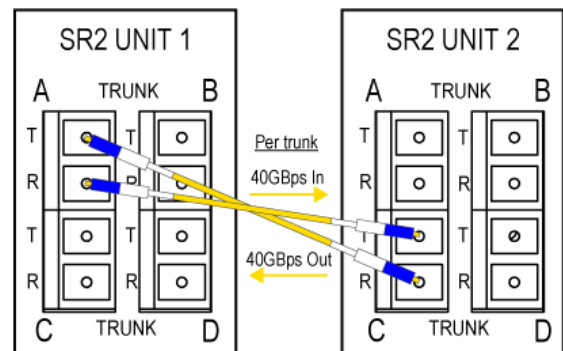

Each trunk is capable of transporting up to 40Gbps of data In and Out. Trunks can be combined to offer more bandwidth or redundancy between network nodes.

1.3.12.2 Transmission principle.

Cf. technical manual for more precisions

1.3.12.3 Trunk types

Internally a Trunk comprises of a QSFP+ mounted and connected inside the machine to the LC/PC sockets on the back of the unit. Different models can cohabitate in the unit depending of customer needs.

There are at least two types of modules available:

STAR2-T4LR: Long Reach optical module offering a guaranteed optical transmission of up to 10km. This is the most common type of Trunk used in Stage Racer 2.

STAR2-T4ER: For much longer distance the Extended Reach optical module is designed for 40Km transmission.

CAUTION: The high sensitivity APD receivers of the T4ER may be destroyed by optical power overload, do NOT apply more than -10dBm on the input port (labelled R). A damaged T4ER receiver port is not covered by warranty.

Similarly if too much power is applied the receiver may overload and the link will not establishes, in this case the optical power reading on the interface may be false as well.

NOTE: The Extended Reach module transmission length it may be affected by fiber chromatic dispersion. Losses in some rare cases of very old fiber.

REMARK: *It is advised to source the QSFP+ at Ereca as factory validates it one by one for compliance with Stage Racer 2 standard. Also the warranty label will be broken.*

1.4 VISUALISATION

The display face provides a comprehensive LED panel of the STAGE RACER 2. For ease of trouble shooting one LED is affected per transmitted signal.

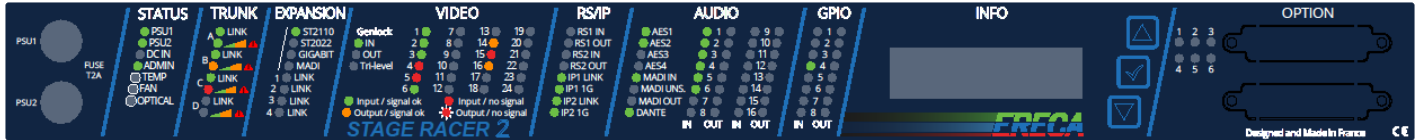

The 2 mains PSU fuses are also located on this side of the equipment for ease of replacement. (Model is 250Vac 2Amp time lag 5x20mm fuse).

1.4.1 General Status

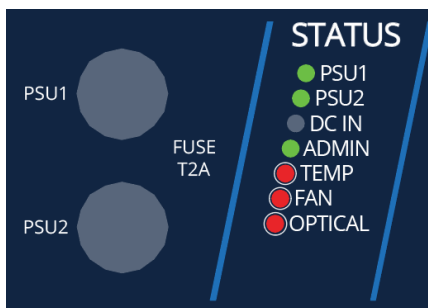

Status related to power supply

- **PSU 1:** Green LED, ON when the PSU module 1 is powered.
- **PSU 2:** Green LED, ON when the PSU module 2 is powered.
- **DC IN:** Green LED, ON when the battery is in use (in that case PSU1 and PSU2 are unpowered)

General

- **ADMIN:** GREEN LED, ON when a connection is established on the admin port.

Technical alarms

- **TEMP:** Red LED, ON when the internal temperature is over 70°C
- **FAN:** Red LED, ON when an internal fan is out of service (Open circuit or Stuck)
- **OPTICAL:** Red LED, ON when the power is low on a connected trunk

1.4.2 Trunks

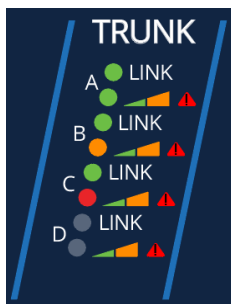

Trunk activity

- **LINK:** Green LED, ON when a connection is established with another machine on that particular trunk port (A, B, C or D).

Trunk occupation

- **LED OFF,** when trunk is not used (occupation at 0%)
- **Green LED, ON** when trunk occupation is between 0% to 49%
- **Orange LED, ON** when trunk occupation is between 50 to 100%
- **Red LED, ON** when there is a problem with the trunk

1.4.3 Expansion

The stage racer 2 offers 4x10GB Ethernet expansion channels via the MPO connector for remote production and future various other applications. As an example of what can be done:

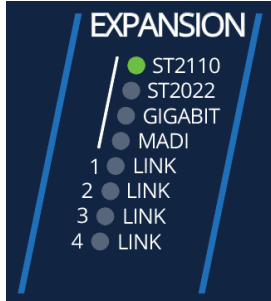

- **ST2110: Green LED, ON** when ST2110 mode is activated in the machine.
- **ST2022: Green LED, ON** when ST2110 mode is activated in the machine.
- **GIGABIT: Green LED, ON** when extra Gbe ports are transmitted.
- **MADI: Green LED, ON** when extra MADI's are transmitted on this machine.
- **Link 1-4: Green LED, ON** to indicate which expansion channel is linked with a peer.

1.4.4 Video Status Leds

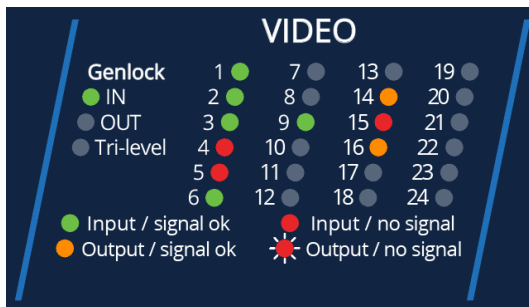

Genlock I/O

- **IN: Green LED, ON** when the unit is Genlock master on the network and a valid Genlock signal is detected on the input.
- **OUT: Green LED, ON** when the unit is Genlock slave on the network and a valid Genlock signal is detected on the output.
- **Tri-Level: Green LED, ON** when a Tri-level signal is detected on the G/L port.

The SDI LED (1 to 24) section indicates the detection of a video signal and its direction.

- **LED OFF**, when the SDI port is disabled via the web interface.
- **Green LED, ON** when the port is configured as Input and a signal is detected conform to its standard.
- **Red LED, ON** when the port is configured as Input, but no signal is received or the signal is not conform to its configured standard. (for example, the port is configured to receive an SD signal but a 3G signal is actually present)
- **Orange LED, ON** when the port is configured as output and a valid signal is routed to that port
- **Red blinking LED, ON** when an input channel is routed to that output port but no signal is detected

1.4.5 Serial and IP

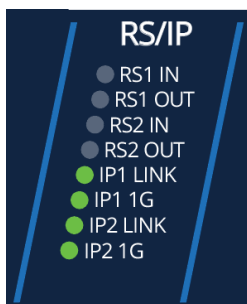

Serial RS

- **RS1 IN, Green LED ON**, when a serial signal is received on the serial port 1
- **RS1 OUT, Green LED ON**, when a serial signal is sent via the serial port 1
- **RS2 IN, Green LED ON**, when a serial signal is received on the serial port 2
- **RS2 OUT, Green LED ON**, when a serial signal is sent via the serial port 2

Ethernet

- **IP1 LINK, Green LED ON**, when an Ethernet link is established on port IP1
- **IP1 1G, Green LED ON**, when the IP link 1 is linked at 1GBps
- **IP2 LINK, Green LED ON**, when an Ethernet link is established on port IP 2
- **IP2 1G, Green LED ON**, when the IP link 2 is linked at 1GBps

1.4.6 AUDIO

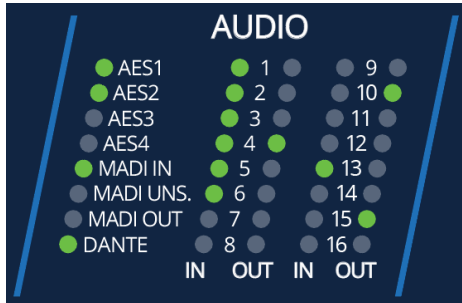

AES/MADI led state depends of the equipment setting (4 AES **or** 2 AES + MADI IN + MADI OUT).

4 bidirectional AES signals.

- **AES 1-4, Green LED ON**, when a 48Khz AES signal is fed on the corresponding port
In that case, All Madi Led are Off.

2 bidirectional AES signals + 1 MADI I/O

- **AES 1-2 Green LED ON**, when a 48KHz AES signal is fed on the corresponding port
- **MADI IN, Green LED ON**, when a MADI signal is received on MADI In Port
- **MADI OUT, Green LED ON**, when a MADI signal is sent on MADI Out Port
- **MADI UNS., Red LED ON**, if the internal reclocker is not locked on the input MADI signal.

Dante

- **Dante, Green LED ON**, when the Dante hardware module is properly installed and recognised by the external Dante controller.

Analog Audio

- **1-16, Green LED ON**, indicates the activity of an analog audio signal received on the input port and/or the output port.

Note: The trigger level is set to -10dBm approximatively. Audio activity LEDs are refreshed every 500ms displaying if there was a level > -10dBm on the past 500ms period providing a smooth display.

1.4.7 GPIO

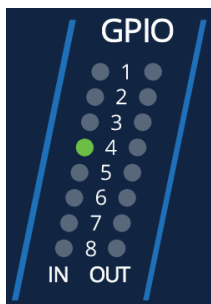

- **GPIO 1-8, Green LED ON**, when a GPI or GPO is activated on their respective input and output.

1.4.8 OLED Display

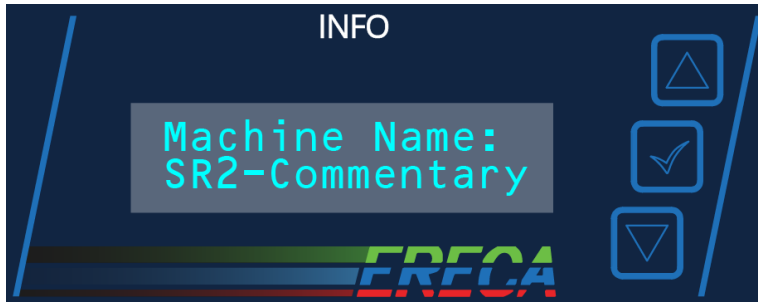

- **Screen**

This section provides a list of real time information for control purposes.

The blue buttons on the right allow navigating between the different information listed below and allows performing a factory reset of the unit. (Need firm finger press in their center).

- **List of messages**

Machine Name: SR2-Commentary	Name of the machine set in the web interface
IP address: 192.168.1.248	IP address of the machine set in the web interface
MAC Address: 507E:EC00:4107	MAC address of the machine
TA Rx 0.2 dBm TB Rx -0.4 dBm	Lowest optical power received on Trunks A & B
TC Rx -6.5 dBm TD Rx -40 dBm	Lowest optical power received on Trunks C & D
Intern Tp 38 Deg Fan Speed 9%	Internal temperature of unit (operating range: -20°C to +60°) Fan speed is automatically adjusted depending on internal temperature
Trunk A load In: 4% Out: 0%	Bandwidth occupation of signals in trunk A In: coming from the distant Node Out: sent to the distant Node
Trunk B load In: 40% Out: 32%	Bandwidth occupation of signals in trunk B In: coming from the distant Node Out: sent to the distant Node
Trunk C load In: 75% Out: 67%	Bandwidth occupation of signals in trunk C In: coming from the distant Node Out: sent to the distant Node
Trunk D load In: 0% Out: 0%	Bandwidth occupation of signals in trunk D In: coming from the distant Node Out: sent to the distant Node

- **Reset from pushbuttons**

The unit can be individually reset to factory default configuration.

It is important to understand all configuration made on this unit will be lost. Therefore, we recommend you to make a backup of the unit via the web interface prior to this operation.

To perform a factory reset:

- Disconnect the unit from the network by temporarily remove the trunks fibers connected to it
- Press and hold the **up** and **down** button for 3s and wait for the message "Press Val..." to appear
- Then the **validate** button on the right side of the screen needs to be pressed within 5s, otherwise, the operation will cancel automatically.
- After the operation is complete, it is recommended to reboot the unit.

1.5 OPTIONAL CONNECTORS

1.5.1 Description

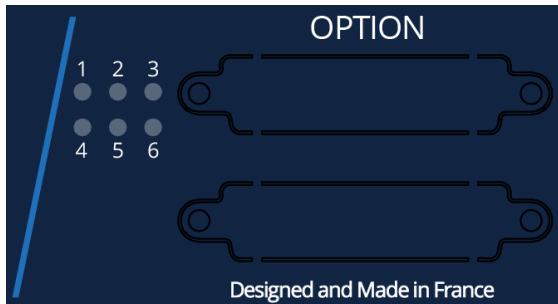

Available hardware options

There are two hardware options available on D-Sub25 connectors:

- **6 additional 500Kbps RS422 channels**
In this case the 6 LED next to the connector will display the IN/OUT activity of each additional serial links.
- **DC input** Provision for D sub socket with power inserts to connect a 10-16 VDC battery to power the Stage Racer 2, used in case of mains power loss.

Caution: The DC input is protected by internal fast acting fuse, any polarity reversal will blow the fuse. Due to the high current involved a resettable protection is not possible.

1.5.2 RS422 option pinout

One D SUB 25 pin female socket provides access to additional RS422 optional channels 1 to 6.

Channel	SIGNAL	Socket contact	D SUB 25 RS422 1to6	Socket contact	SIGNAL
1 (3)	IN 1 -	1		14	IN 1 +
1 (3)	OUT 1 +	2		15	OUT 1 -
2 (4)	IN 2 -	3		16	IN 2 +
2 (4)	OUT 2 +	4		17	OUT 2 -
3 (5)	IN 3 -	5		18	IN 3 +
3 (5)	OUT 3 +	6		19	OUT 3 -
all	GND	7		20	IN 4 -
4 (6)	IN 40 +	8		21	OUT 4 +
4 (6)	OUT 4 -	9		22	IN 5 -
5 (7)	IN 5 +	10		23	OUT 5 +
5 (7)	OUT 5 -	11		24	IN 6 -
6 (8)	IN 6 +	12		25	OUT 6 +
6 (8)	OUT 6 -	13			

Remark: (x) denotes the logical channel in the GUI.

It is strongly recommended to connect the shield of the signals transmitted to the GND pin.

Each LED summarize the Input and Output signal activity on the corresponding channel. Each signal activity is also reported on the web interface.

Each differential input is not 120Ohms loaded internally for optimum compatibility with transmitted protocols. If impedance matching is needed a small SFR16 resistor could be added directly on the D SUB pins, together with the signal wire.

Note 1: For RS 485 Telex/RTS talkback panels please ask ERECA for wiring tip.

Note 2: As the differential inputs are unloaded internally a small crosstalk should happen on the adjacent channel only if it is unused and left floating.

2 TECHNICAL SPECIFICATIONS

2.1 MAIN HARDWARE

Optical	
Trunk	4 optical fiber trunks per unit providing a total of 160GBps of data traffic In and Out 10Kkm of single mode fiber / Link power budget 10dB / LC/PC connector (Optionally 40Km range)
SDI Video	
Number, connector:	12 or 24 Channels (Each channel is direction configurable), 75Ω BNC
Standard (Upper row):	SD, ASI, HD, 3G / BNC Connector
Standard (Mid row):	SD, ASI, HD, 3G / HD-BNC Mini Connector
Standard (Lower row):	SD, HD, 3G, 6G, 12G / BNC Connector
Return loss:	Better than -15 dB for 0 to 1,5 GHz / -10 dB for 1,5 to 3 GHz / -6 dB for 6 to 12 GHz
Composite Video / GL	
Number:	1 port, direction configurable / 75Ω BNC connector
Standard:	PAL, NTSC Composite / Black Burst / Tri-level (Auto sense) Genlock clock may not support all formats
Bandwidth:	> 5,8 MHz at +/- 0,2 dB
Differential Gain/Phase:	< 1%, < 1°
Group delay:	< 10 ns
SNR:	> 67 dB (CCIR567)
Analog Audio	
Number, connector:	16 inputs, 16 outputs channels, D-SUB 37 female socket
Impedance:	Input: 10 KΩ differential (non-floating), Output: 20Ω differential (non-floating)
Amplitude:	+4 dBm nominal (saturation at +18 dBm)
Bandwidth:	50 Hz to 15 kHz at +/- 0,5dB (20 Hz to 20 kHz at -3 dB)
Distortion:	0,05% at 1kHz +18 dBm
Signal to noise ratio:	90dB, "A" weighted
Mic preamp option:	Gain from 10 to 60dB (3dB steps) / Phantom power / Preamp Bypass (8 preamp fitted on channels 9 to 16)
Digital audio	
AES ports:	4 bidirectional ports (Intercom panel compatible) / 75 Ω BNC connector / Shared with Madi port BNC
MADI port:	1 input, 1 output / 48 kHz support (SRC) / 75 Ω BNC connector
DANTE-AES67 option:	Dante and AES67 support / 64 channels / 48 kHz support (SRC) / Routed to the gigabit ports
Serial	
Number, connector:	2 bidirectional channels, 1 RJ45 socket per channel
Protocols:	RS485, RS422, RS232
Data rate:	0 to 500 KB/s (Sony compatible)
RS422 option:	6 bidirectional RS422 / 0 to 500 KB/s (Sony compatible) / D-SUB 25 female socket on front side
Ethernet	
Number, connector:	2 independent channels, RJ45 Socket
Protocols:	10, 100 or 1000 Mb/s, Full or Half-duplex (Auto), MDI or MDI-X (Auto)
GPIO	
Number, connector:	8 bidirectional GPIO contacts / 6 on D-SUB 15 female plus 1 GPIO along each RJ45 Serial connector
Output:	Relay (dry contact) 'Common' – 'Normally Open' terminals for each relay
Input:	Floating on the D-SUB, Input pin grounding on RJ45
Powering	
Consumption:	80 Watts per unit maximum (All trunks and all signals used + IP module active)
Mains source:	Dual redundant built in PSU / Voltage range 90 to 260 VAC / 47 to 63 Hz
Low voltage option:	10 to 16 VDC / D-SUB 25 with power inserts (fitted on front side) / protected by internal fast acting fuse
Mechanical	
Size:	1 RU 19" rack, depth 335mm excluding connectors
Weight:	4.5 Kilograms
Cooling:	Internal fan tray with transversal cooling flow / side panels in/out / Passive heatsinks on actives
Operating temp range:	From -20 to + 60°C (Avoiding direct sun exposition)
Signaling / Admin	
Local display:	OLED display for main parameters (IP add / Optical power) / 1 LED per signal / Technical alarms LED
Setup:	Web interface / 3 rd party automation protocols (Cerebrum, KSC Core, VSM....)
Connection:	1 dedicated 10/100Mbs ethernet port

2.2 OPTIONS

STAGE RACER 2 OPTIONAL MODULES (retrofit possible)	
OPTION - Analog Audio Mic preamp / 48V	
Input:	8 Microphone input gain blocks fitted on channels 9 of the 16.
Mic input, Gain:	Gain from 10 to 60dB (3dB steps) / Preamp Bypass, through internal Web Server.
Phantom power:	48 volts switchable, through internal Web Server, Source Impedance 6.8 KΩ.
OPTION - Dante/AES67	
Number, connector:	64 bidirectional channels / 48Khz support (SRC) / Routed to the gigabit port IP1.
Protocols:	Dante/AES67
OPTION - Serial	
Number, connector:	6 bidirectional channels, D-SUB 25 female socket on front side.
Protocols:	RS422
Data rate:	0 to 500 Kbps (Sony compatible)
OPTION - Battery powering	
Low voltage option:	10 to 16 VDC / D-SUB 25 with power inserts (fitted on front side) / protected by internal fast acting fuse.