

Decentralized TRANSMISSION, ROUTING, DISTRIBUTION and PROCESSING range of products

Family overview



StageRacer2



CoreRacer



MiniRacer 2



MiniRacer 2 Rugged

Product Highlights

StageRacer2, MiniRacers2 and CoreRacer share the same TDM fiber protocol and can be connected together to create a meshed network across Trunk lines covering all broadcast need.

StageRacer2 and MiniRacer2 are designed to accept all kinds of signals on a same device without external adapter. Internally those signals can be associated together / routed / distributed to all other machines of the network.

CoreRacer is designed to aggregate all frames across a venue and deliver those signals at the control room side. CoreRacer's can also be connected together by high speed HyperTrunk lines working at 200Gbs, those Hyper trunk will also serve for bridging from Stage Racer2 ecosystem to an ST2110 Core.

All those frames also offers processing capabilities with Multiviewer, Audio Embedding/De-embedding, Audio shuffling, Audio SRC, Frame buffering, Delays and Tico compression (StageRacer2 only).

TV compound application example

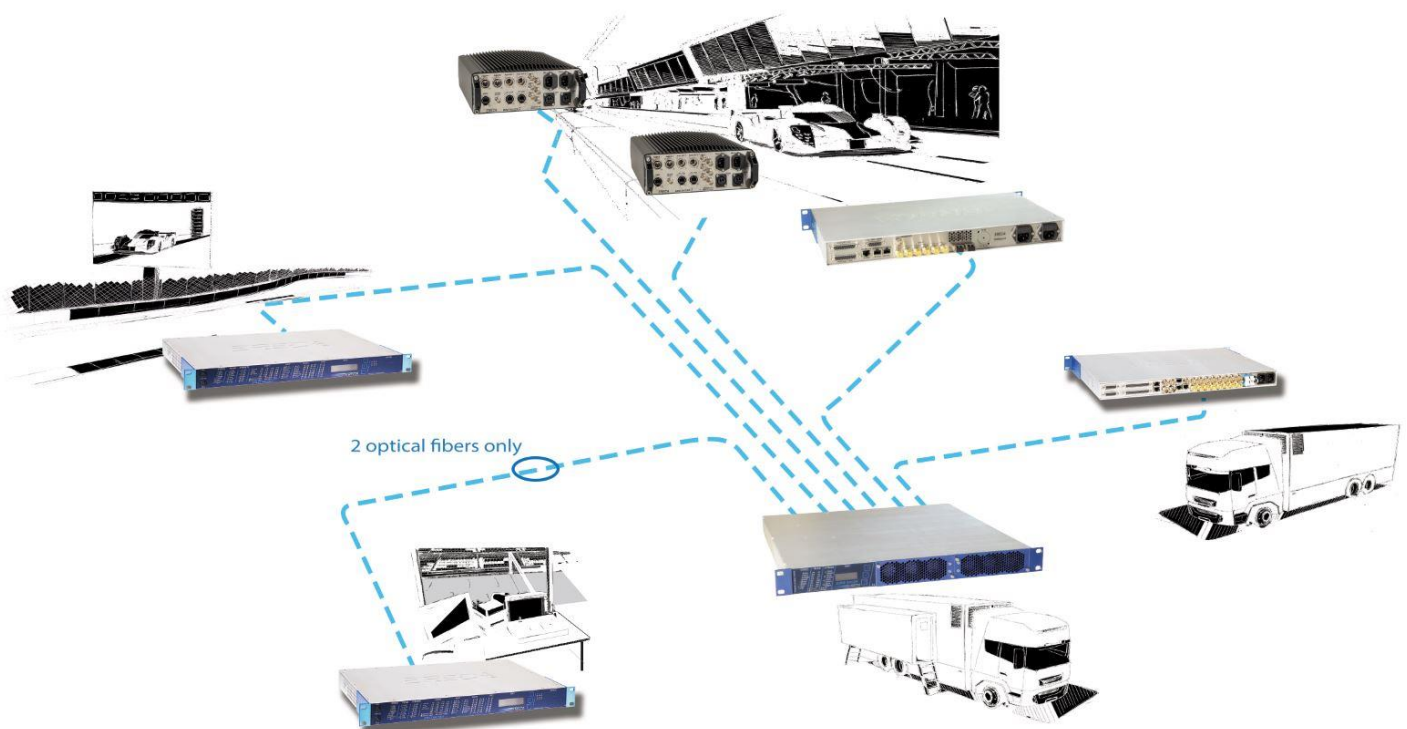

Video & Audio Processing

To ease system setup and provide a seamless integration the StageRacer2's family offers the following processing capabilities:

Multiviewers: Each frame offers a powerful Multiviewer allowing to monitor inputs or outputs of the network. Each thumbnail feature Audio level monitoring, Tally, SDI format display. Each Multiviewer output is routable or distributable over the whole StageRacer's network, also each Multiviewer output picture can be viewed from the web Gui. This feature comes without license neither performance reduction.

Frame synchronizers & Delays: Each offers frame synchronizers (see tech specs for more infos)

Embedding/De-embedding: Audio can be inserted or extracted from any SDI port of the system.

Audio Processing / Shuffling: Any audio source can be routed to any kind of audio output. To allow that, each digital audio input (SDI De-embedded / Dante-AES67) enters the transmission engine thru an SRC to be at the same rate as the analog channels. Inversely each output (SDI Embed / Dante-AES67) will exit the transmission engine thru an SRC.

Colorbar insertion: To ease setup when no signal is fed into an SDI input, an internal Colorbar with an embedded text label is internally generated and routed instead of the SDI. A tone generator is also available into the audio matrix.

Redundancy: Desired SDI signals travel a duplicated path across the network for seamless switch if a path fails.

Management interface / Routing / Offline configurator

All the configuration is done through a standard HTML web interface. Through this interface the user can:

- Explore the network topology (automatic topology discovery),
- Route and distribute all signals (audio, video, multiviewer outputs, IP, Serial, GPIO, ...),
- Control the processing (Embedding/De-embedding, Multiviewers, Frame-syncs, Pattern insertion).
- Monitor status (link saturation, optical losses, redundancy, signal status, signal path used, logs),
- Set priorities for important signals and declare dual path setting for seamless redundancy.
- Preview (SDI's and its audio activity, Multiviewer out) directly from the web Gui.

An offline configuration tool (web based) is available to prepare topologies and routing setups. Setting files can then be downloaded from the tool. Also an existing setup can be uploaded into the tool for offline modifications.

The fiber network topology is automatically detected and signals are dynamically re-routed in case of link breakage, high priority signals are re-routed first.

The architecture is completely decentralized, if any node is added or removed the rest of the network will automatically detect the new topology and keep working as intended. It is also possible to temporarily connect multiple networks to mutualize resources for big events without having to reconfigure the entire system.

Cooling / Power / Options

MiniRacer2 and StageRacer2 frames achieves a very efficient and silent cooling thanks to a thorough design on internal heatsinks. Temperature raise on the mother boards is kept under 25°C at the fans lower speed making this product a good choice for outside applications. Additionally the very low power consumption make those units a good choice for CSR demanding applications.

Each unit has a built-in redundant power supply. An optional DC camera battery power input can act as a third power source on the MiniRacer2.

Optionally a 4 (MiniRacer2) or 8 (StageRacer2) channel mic preamp plus phantom power, a 6 hi-speed serial channels and a 6 AES expansion module are also available.

Dante interface card with 64ch I/O can be integrated in StageRacer2 and MiniRacer2 rack unit.

CoreRacer is powered by two hot swappable redundant power supply (standard server type) with current share. The PSU have their own fan and cooling channel, additionnaly two ERECA designed hot swappable fan Trays ensure the cooling of the motherboard.

Signal Transmission

Transmission is based on TDM multiplexing for the all signals managed by the system, each TDM multiplex is transmitted to another machine by “Trunk” ports working at 40Gbs. StageRacer2 can be equipped with up to 4 Trunks and MiniRacer2 can be equipped with 2 Trunks maximum.

The CoreRacer offers 16 such Trunks plus 4 HyperTrunks working at 200Gbs to connect cores together or use it as a bridge to 2110. Additionnally those HyperTrunks can be down-graded to 100G and 40G depending application, especially to offer more 40G trunks.

Considering a standard 40G Trunk, most part of the bandwidth is dynamically allocated for high data rate signals (SDI / Ethernet / Raw signals). A small remaining bandwidth is fixed and guaranteed, dedicated to low data rate signals (Genlock / Audio / Serial / GPIO / System management) with a predefined maximum channel capacity per signal type.

As a base rule, each trunk total I/O capacity is:

- 25 HD signals (or similar rate signals like GB Ethernet), or 12x3G or 3x12G or any combination,
- 1 Genlock / Tri-level / Composite,
- 400 Bidirectional Processed Audio channels,
- 50 Bidirectional Serial channels,
- GPIO for 256 frames.

For SDI, routing engine will send the signals at the desired points only, after this point the signal is not carried on the network and its bandwidth is available.

For audio all required signals will be allocated one of the 400 channels and routed elsewhere in the network. The same principle is applied to GPIO and Serial channels and allow signal distribution or point to point transmission.

Regarding audio processing, 400 channels are available for all audio signals that need to be embedded or de-embedded to be routed anywhere in the network. Audio processing does not affect the audio transport capabilities that remains virtually unlimited by the use of AES, Embedded SDI or Networked audio raw transport.

For contribution and remote production applications, the SR2 network can be expanded worldwide through Telco services. SR2 proprietary signal is internally formatted to enter a standard Telco operator interface and to be delivered synchronously with minimal delay thousands kilometers away. SDI signals are transmitted bit accurate without compression.

Note: Into the CoreRacer the SDI channels are remapped into 1000 virtual channels and audio is remapped into 8000 virtual channels to maintain channels capacity across the whole system.

MiniRacer2 details

MiniRacer2 is designed as a member of the StageRacer 2 family and is compatible with existing StageRacer2 frames and the CoreRacer. With its 6 non blocking 12G direction switchable SDI ports it is a perfect fit for UHD stageboxes and small stageboxes for commentary positions or big screen feed on a venue.

The MiniRacer2 is available in two form factors, A 1RU rack integration and a Rugged box integration for direct outside use without the need of a flight case integration with patch panels.

Each SDI ports are 12G direction configurable, plus a common set of signals. Each equipment assumes transmission of a comprehensive set of signals as follows:

Mini Racer 2 – 1 RU version	Mini Racer 2 – Rugged version
6 SD to 12G direction switchable SDI channels	
Distributed Genlock (Composite video / Black burst / Tri-level)	
8 Analog Audio I/O (optional 4ch Mic gain / Phantom 48V module) on D-SUB 25 connector.	2 Analog Audio I/O (optional 4ch Mic gain / Phantom 48V module)) on dedicated XLR's.
2 Ethernet 10/100/1000Mbs + POE source (optional 64ch Dante/AES-67 module on port 1)	2 Ethernet 10/100/1000Mbs + POE source
1 Data RS 422 on D-SUB 15 connector (+ optional 6x 500Kbps RS422 ch. ^(*)).	None – Possible on rear D-SUB 15 option.
2 GPIO on D-SUB 15 connector.	None – Possible on rear D-SUB 15 option.
2 AES3 bidirectional on D-SUB 15 connector. (Intercom panel compatible) + optional 6 ch. ^(*)	None – Possible on rear D-SUB 15 option.

* AES option and Serial RS422 option expansion board are exclusive and cannot be fitted at the same time. Also its only fits on 1RU housing.

** D-SUB 15 connector is a shared connector with AES, GPIO and Serial together.

StageRacer2 details

The StageRacer2 is available in two standard configurations: 24 or 12 SDI channels, direction configurable, plus a common set of signals. Each equipment assumes transmission of a comprehensive set of signals as follows:

Stage Racer 2 – 24 SDI version	Stage Racer 2 – 12 SDI version
16 SD to 3G direction switchable channels	8 SD to 3G direction switchable channels
8 SD to 12G direction switchable channels	4 SD to 12G direction switchable channels
1 Distributed Genlock (Composite video / Black burst / Tri-level)	
16 Analog Audio I/O (optional 8ch Mic gain / Phantom 48V module)	
2 Ethernet 10/100/1000Mbps (optional 64ch Dante/AES-67 module on port 1)	
2 Data RS 232/422/485 (optional 6 additional 500Kbps RS422 serial channels ^(*))	
8 Contact closures	
4 AES3 bidirectional (Intercom panel compatible / Optional 6 additional ^(*))	
1 MADI I/O (AES10) signal (Shared with 2 of the 4 AES connectors)	

^{*} AES option and Serial RS422 option expansion board are exclusive and cannot be fitted at the same time.

Each SDI port can be independently configured as an input or an output for asymmetrical usage at central points.

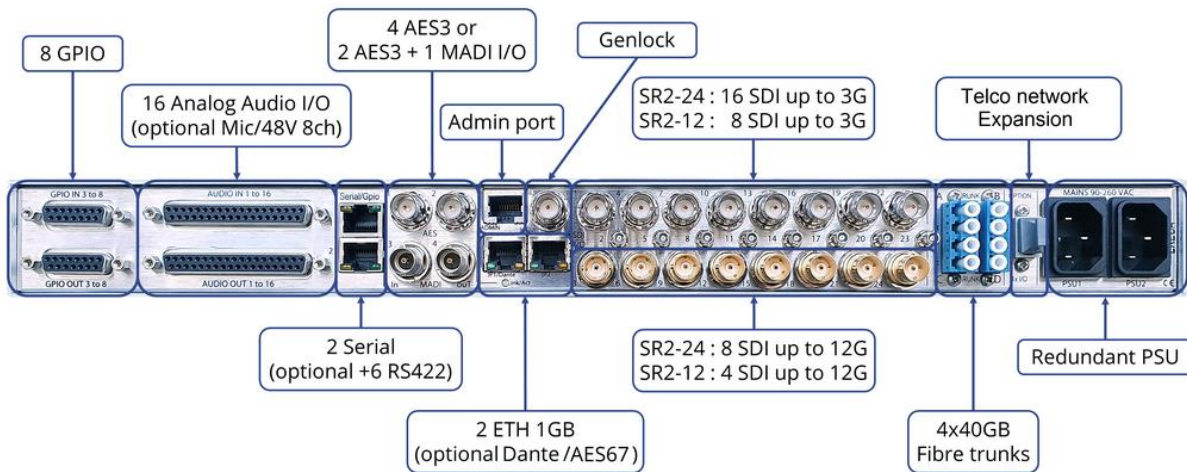

CoreRacer details

The CoreRacer first acts as an aggregation device for MiniRacers2 and StageRacers2 allowing to build wider networks with no congestion concerns.

The CoreRacer basically offers 16 Trunks working at 40Gbs plus 4 HyperTrunks working at 200Gbs to connect Cores together or use it as a bridge to 2110 at a second design stage. Additionally those HyperTrunks can be down-graded to 100G and 40G depending application, especially to offer up to 20 trunks at 40G on the same frame.

Physically 8 Trunks are embedded into the frame and 8 Trunks are externally located at the rear of the frame and can be exchanged depending customer needs to extend fiber distance or to add our patented interface to add SDI I/Os on the frame. Each patented interface allow 4x 12G SDI Inputs plus 4x 12G SDI Outputs non blocking. The 4 HyperTrunks are also located at the rear of the frame.

The CoreRacer have genlock I/O port and feature a powerful memory bank allowing more than 20x 12G SDI frame syncs.

The 2 PSU can be removed by the rear of the frame by releasing the latching tab, and the 2 fan trays located in the front and can be removed easily by unscrewing 2 knurled captive screws, while electrical connection is easy made by piston contacts.

Web management insight

The Graph page is the place where everything starts, it is possible to:

- See whole network topology and condition (PSU state / Critical Alarms / Trunk occupancy),
- Use the left pane to navigate in the machine tree view and activate signals to get it in the desired routing matrix,
- See the detailed state of each machine by just clicking on it and looking the status pane.

Network Graph, Device/Port configuration interface, Live Status, Audio Activity and Logs

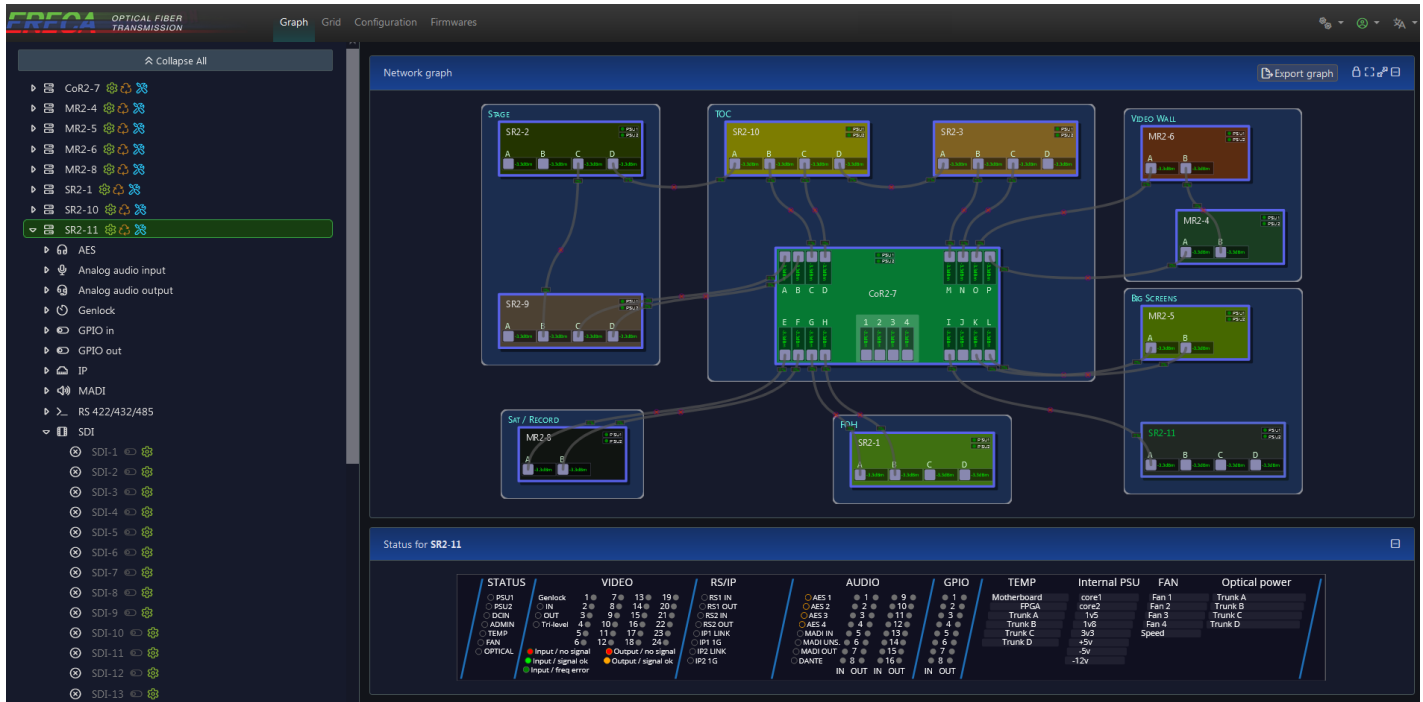

Once done, the Grid page allows to route each kind of signals between in and out activated ports over the whole StageRacer2 frames network.

Grid view with cross-points matrix, filters, routing indications, signal status, live preview.

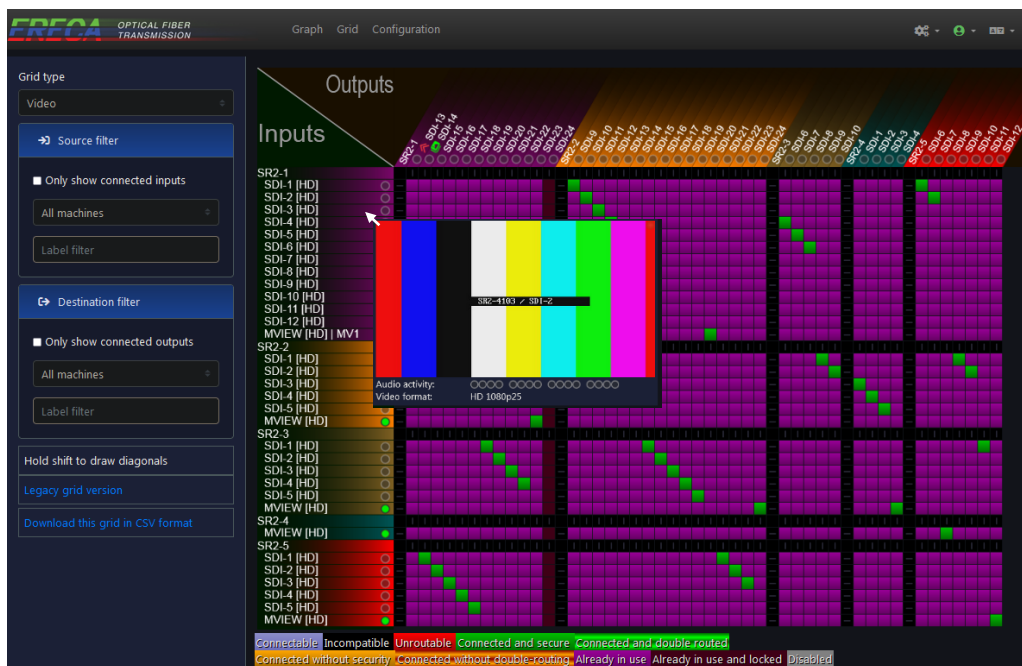

Technical specifications

Optical		[Legend : MR2 = MiniRacer2 / SR2 = StageRacer2 / CORE = CoreRacer]
Trunk / HyperTrunk:	2 (MR2), 4 (SR2) or 16 (CORE) optical 40Gbs fiber trunks per frame, 10Km of single mode fiber, LC/PC 4 (CORE) optical 200Gbs HyperTrunk / 2Km of single mode fiber, LC/PC	
SDI Video		
MiniRacer 2:	6 Channels 12G (Each channel is direction configurable), 75Ω BNC	
StageRacer 2-12:	4 Channels 12G + 8 Channels 3G (Each channel is direction configurable), 75Ω BNC / MiniBNC mix	
StageRacer 2-24:	8 Channels 12G + 16 Channels 3G (Each channel is direction configurable), 75Ω BNC / MiniBNC mix	
CoreRacer:	Pluggable modules with 4 Channels 12G in + 4 Channels 12G out, MiniBNC, (SD not supported)	
Standard:	SD, HD, 3G, 6G, 12G / BNC Connector – Not all port supports SD, 6G, 12G as stated above	
Return loss:	Better than -15 dB for 0 to 1,5 GHz / -10 dB for 1,5 to 3 GHz / -6 dB for 6 to 12 GHz	
Composite Video / GL		
Number:	1 port, direction configurable / 75Ω connector (BNC for SR2 and MR2 / Hd BNC for Core)	
Standard:	PAL, NTSC Composite / Black Burst / Tri-level (Auto sense) Genlock clock may not support all formats	
Performance:	Bw > 5,8 MHz at +/- 0,2 dB - DgDp < 1%, < 1°- Group delay < 10 ns – SNR > 67 dB (CCIR567)	
Analog Audio		
Number, connector:	16 inputs, 16 outputs channels, D-SUB 37 female socket on SR2 8 inputs, 8 outputs channels, D-SUB 25 female socket (Tascam pinout) on MR2 1RU chassis 2 inputs, 2 outputs channels, XLR on MR2 Rugged integration.	
Impedance:	Input: 10 KΩ differential (non-floating), Output: 20Ω differential (non-floating)	
Amplitude:	+4 dBm nominal (saturation at +18 dBm)	
Performance:	Bw 50 Hz to 15 kHz at +/- 0,5dB (20 Hz to 20 kHz at -3 dB), Thd 0,05% at 1kHz +18 dBm, SNR 90dB 'A'	
Mic preamp option:	Gain from 10 to 60dB (3dB steps) / Phantom power / Preamp Bypass 8 preamp fitted on channels 9 to 16 on SR2, 4 preamp fitted on channels 1 to 4 on MR2	
Digital audio		
MiniRacer 2:	2 AES3 bidirectional ports (Intercom panel compatible) / 75 Ω / D-SUB 15 female shared connector	
StageRacer 2:	4 AES3 bidirectional ports (Intercom panel compatible) / 75 Ω / BNC / 2 are Shared with MADI 64ch In & Out	
DANTE-AES67 option:	Dante and AES67 support / 64 channels / 48 kHz support (SRC) / Routed on port IP1 / Not on Rugged	
Serial		
MiniRacer 2:	1 bidirectional channel, D-SUB 15 female shared connector / Not on Rugged	
StageRacer 2:	2 bidirectional channel, RJ45	
Protocols / Data rate:	RS422 MR2,SR2 + RS232/RS485 SR2 / 0 to 500 KB/s (Sony compatible)	
RS422 option:	6 bidirectional RS422 / 0 to 500 KB/s (Sony compatible) / D-SUB 25 female socket on 1RU front side	
Ethernet		
Number, connector:	2 independent channels, RJ45 Socket	
Protocols:	10, 100 or 1000 Mb/s, Full or Half-duplex (Auto), MDI or MDI-X (Auto)	
Power over Ethernet:	Up to 15 watts (POE) per port or a single port with 30W (POE+) / Only on MR2 and MR2 Rugged	
PTP support:	Dynamic adjustment of PTP packets reflecting travel time between IP ports on the StageRacer2 network	
GPIO (1RU)		
MiniRacer 2:	2 bidirectional GPIO contacts / D-SUB 15 female shared connector	
StageRacer 2:	8 bidirectional GPIO contacts / D-SUB 15 female connectors	
Interface:	In: Floating thru photocouplers / Out: Independent Dry contacts 'Common' – 'Normally Open'	
Consumption / CSR		
MiniRacer2:	35 Watts per unit maximum (All trunks and all signals used) / Low voltage option 14 to 18 VDC / XLR	
StageRacer2:	90 Watts per unit maximum (All trunks and all signals used based on 24 channel frame)	
CoreRacer :	300 Watts per unit maximum (All trunks and all Hypertrunks used)	
Mains source :	Dual redundant built in PSU / Voltage range 90 to 260 VAC / 47 to 63 Hz. Hot swappable for the Core.	
CSR:	Locally built, Low power consumption v/s performance, Recyclable case material (metal), Low plastic.	
Mechanical		
Size (1RU Models):	1 RU 19" rack, depth 255mm MR2, depth 312mm SR2, depth 420mm CORE / excluding connectors for all	
Size (MR2 Rugged):	260mm width x 325 depth x 108mm height, excluding connectors and handles	
Cooling (1RU models):	Internal fan tray with transversal cooling flow / side panels in/out / Passive heatsinks on actives	
Cooling (MR2 Rugged):	Internally cooled, Heat dissipated thru a dust proof heatsink style housing.	
Weight:	2.5 Kilograms MR2, 5.5 Kilograms MR2 RUGGED, 4.5 Kilograms SR2, 6.5 Kilograms CORE.	
Operating temp range:	From -20 to + 60°C (Avoiding direct sun exposition)	
Signaling / Admin		
Local display:	OLED display for main parameters (IP add / Optical power) / 1 LED per signal / Technical alarms LED	
Setup:	Web interface / 3 rd party automation protocols thru Ember+ (VSM, Cerebrum, KSC Core, Hi,)	
Keypanels:	Direct interface with Black-Magic keypanels, Stream deck + Companion software, Companion Plugin....	
Connection:	1 dedicated 10/100 ethernet port.	

© 2026-04-08 Ereca SAS. All rights reserved. Product specifications are subject to change without notice.
All ERECA Products are DESIGNED and MADE in FRANCE.